

Andor's SX cameras mounted inside a Vacuum Chamber.

Courtesy of Queen's University Belfast



High Energy Detection

Features and Benefits

- Vacuum compatible¹**
 System can be placed inside the vacuum chamber to minimize the distance between the source and the detector to maximize signal capture.
- Highly shielded PCI connection**
 The single highly shielded data and power interface cable allows unaffected operation in Harsh EM environments.
- Integrated filter holder**
 This allows easy mounting of standard filters.

In Vacuum Direct Detection

Andor's Classic SX series features high-QE sensors for direct detection of soft X-ray, EUV or VUV photon ranges. The vacuum compatible system is ideal for use inside vacuum chambers.

With a variety of sensor array and pixels sizes we offer a range of options to optimize in vacuum camera performance for your application.

Our range of software options allowing seamless integration and control within larger setups. The highly shielded single data and power cable enables operation even in the harshest environments.

Specifications Summary

Sensor type	20	20 'DD'	40	34
Active pixels	1024 x 255	1024 x 256	2048 x 512	1024 x 1024
Pixel size (W x H)	26 x 26 μm	26 x 26 μm	13.5 x 13.5 μm	13 x 13 μm
Image area	26.6 x 6.7 mm	26.6 x 6.7 mm	27.6 x 6.9 mm	13.3 x 13.3 mm
Register well depth	1,000,000 e ⁻	1,400,000 e ⁻	600,000 e ⁻	200,000 e ⁻
Maximum cooling	-100°C			
Maximum Spectra Per Sec @ 1MHz	166	166	90	-
Maximum Frame Per Sec @ 1MHz	-	-	-	0.9
Read noise @ 1 MHz	18	18	7	7.5
Vacuum compatible	10 ⁻⁵ millibar and below			

System Specifications

Model number	DX420	DX420-**-DD	DX440	DX434
Sensor options	BN: Back illuminated CCD, no AR coating FI: Front illuminated CCD, no AR coating	BR-DD: Back illuminated CCD, Deep Depletion NIR AR coating FI-DD: Front illuminated CCD, Deep Depletion, no AR coating	BN: Back illuminated CCD, no AR coating	BN Back illuminated CCD, no AR coating FI: Front illuminated CCD, no AR coating
Active pixels *2	1024 x 255	1024 x 256	2048 x 512	1024 x 1024
Pixel size	26 x 26 μm	26 x 26 μm	13.5 x 13.5 μm	13 x 13 μm
Image area	26.6 x 6.7 mm	26.6 x 6.7 mm	27.66 x 6.9 mm	13.3 x 13.3 mm

Advanced Performance Specifications *4

Dark current, e ⁻ /pixel/sec @ max cooling ⁴	FI	BN	FI-DD	BR-DD	All types	All types
Without PSU and conduction only	0.0012	0.0024	0.31	0.71	0.003	0.0005
Without PSU and coolant chiller, coolant @ 10°C, 0.75 l/m	0.00063	0.0013	0.07	0.12	0.00017	0.00028
With PSU and conduction only	0.0008	0.0018	0.16	0.28	0.0002	0.00035
With PSU and coolant chiller, coolant @ 10°C, 0.75 l/m	0.00053	0.0011	0.008	0.013	0.00014	0.00023
Pixel well depth	500,000 e ⁻		510,000 e ⁻		80,000 e ⁻	100,000 e ⁻
Register well depth	1,000,000 e ⁻		1,400,000 e ⁻		600,000 e ⁻	200,000 e ⁻
Read noise (e⁻) *5						
31 kHz pixel readout rate	4		5		2.5	2.6
1 MHz pixel readout rate	18		18		7	7.5
Sensitivity (e⁻/count)	10,7,3.5		10,7,3.5		2,1.4, 0.7	2,1.4, 0.7
Vertical clock speed *6	16 μs					
Linearity *7	better than 99%					
Digitization	16 bit					
Maximum bakeout temperature	+55°C					
Vacuum compatibility	10 ⁻⁵ millibar and below					

Cooling Options

Minimum temperatures *3	Without PS150	With PS150
Conduction only	-75°C	-80°C
Coolant chiller, coolant @ 10°C, 0.75l/m	-85°C	-100°C
Blemish specifications	Grade 1 sensor	

Quantum Efficiency Curves ^{*9}

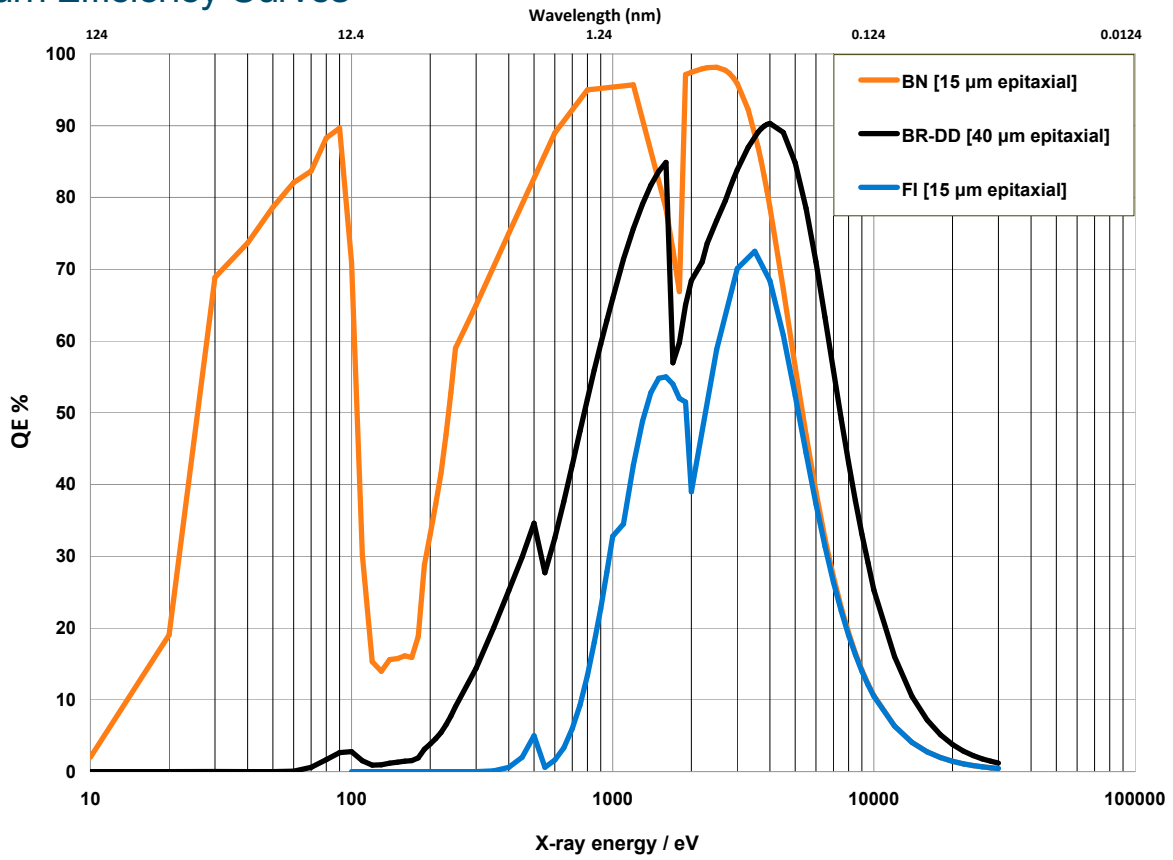

Photoelectrons v Incident X-rays ^{*10}

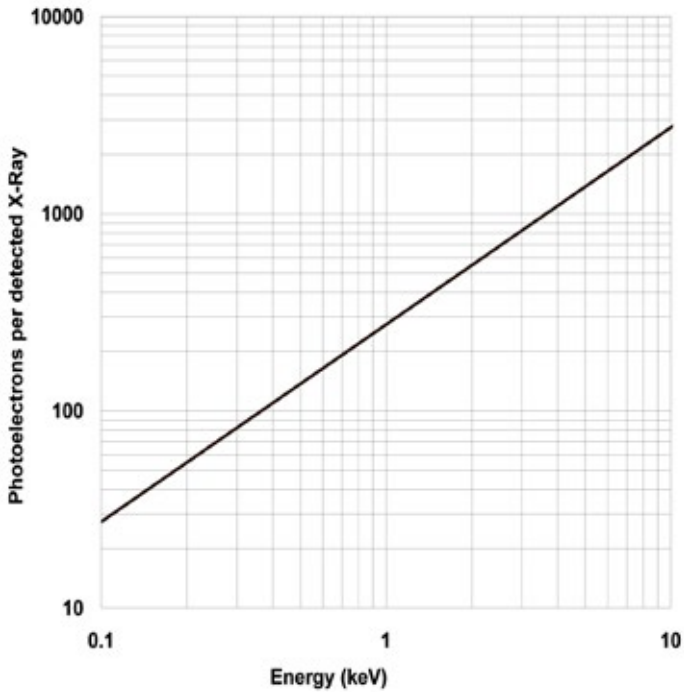

Typical Camera setup

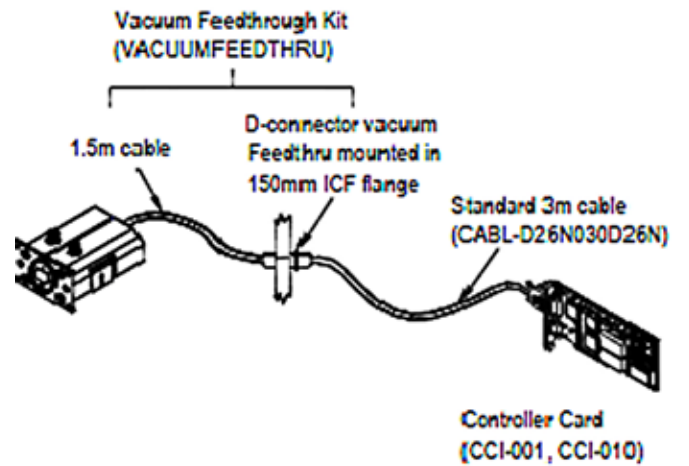

Allow 140mm clearance for the cable at the back of the detector.

Creating The Optimum Product for You

How to customize the Classic SX DV series:

Step 1.

Simply select from the four sensor array types that which best suits your needs.

Step 2.

The Classic SX CCD comes with four options for sensor types. Please select the sensor which best suits your needs.

Step 3.

Please select PCI card.

Step 4.

Please indicate which software you require.

Step 5.

For compatibility, please indicate which accessories are required.

Step 6.

Please indicate any special requirements.



Step 1.

Choose sensor array

420: 1024 x 255 pixel array
420 'DD': 1024 x 256 pixel array
440: 2048 x 512 pixel array
434: 1024 x 1024 pixel array

Step 2.

Choose sensor type

BN: Back Illuminated CCD, with no AR coating
FI: Front Illuminated CCD, with no AR coating. (420, 434 only)
BR-DD: Back Illuminated, Deep Depletion CCD, with AR coating and fringe suppression. (420 'DD' only)
FI-DD: Front Illuminated, Deep Depletion CCD, with no AR coating (420 'DD' only)

Step 3.

Step 1. The Classic SX also requires a PCI card to operate:

CCI-010 PCI Controller card with 16-bit 1MHz, 500 kHz, 62 kHz and 31kHz pixel readout rates with 3 m detector cable

Step 4.

The Classic SX requires at least one of the following software options:

Solis Imaging A 32-bit application compatible with 32 and 64-bit Windows (XP, Vista and 7) offering rich functionality for data acquisition and processing. AndorBasic provides macro language control of data acquisition, processing, display and export.

Andor SDK A software development kit that allows you to control the Andor range of cameras from your own application. Available as 32 and 64-bit libraries for Windows (XP, Vista and 7), compatible with C/C++, C#, Delphi, VB6, VB.NET, LabVIEW and Matlab. Linux SDK compatible with C/C++.

Step 5.

The following accessories are available:

XW-RECR Re-circulator for enhanced cooling performance
 ACC-XW-CHIL-160 Oasis 160 Ultra compact chiller unit
 VACUUMFEEDTHRU Flange with connector and 1.5 m detector cable [See page 3]
 PS150 Optional external power supply
 IO 160 Multi I/O box for interface signals
 IO 165 Advanced multi I/O box with DAC and ADC
 ACC-MEC-01474 Copper block for water cooling in vacuum

Have you found what you are looking for?

Need a wider field of view? Andor's Classic SX DV Series DX436 boasts a 27.6 mm x 27.6 mm active image area.

Need to detect harder X-rays? Andor offers a range of Indirect Detection cameras (HF range) that are compatible with industry-standard scintillators.

Need a standalone camera for X-ray? A custom built Beryllium window is fitted as standard to our SY/HY range of cameras to block visible light.

Need a specific mounting? Contact our experienced design team so we can make the perfect fit.

Need a customised version? Please contact us to discuss our options.

Product Drawings

Dimensions in mm [inches]

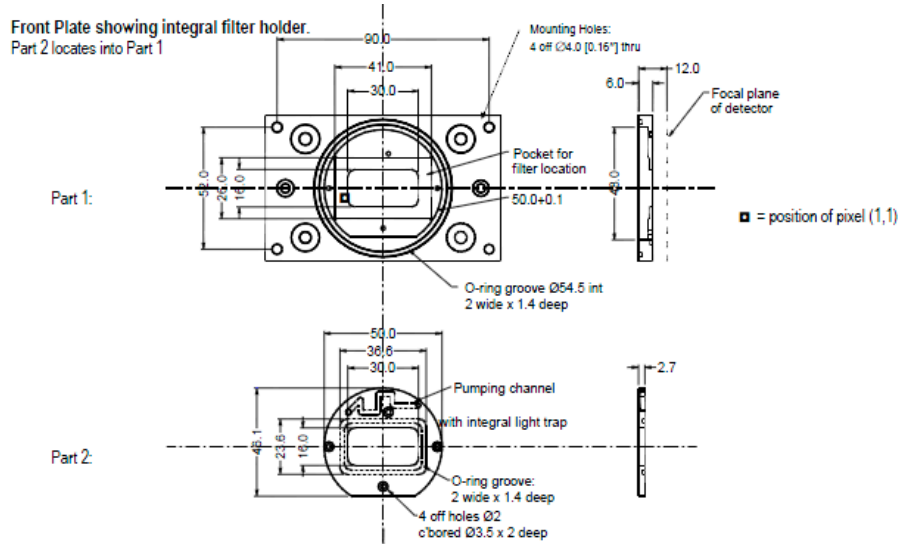
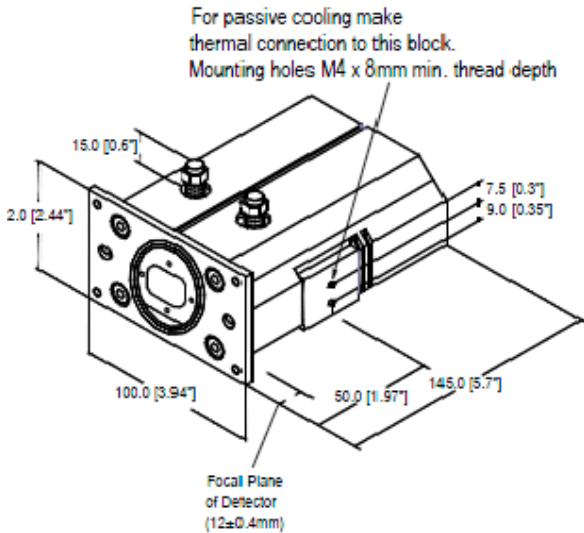
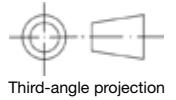

Weight: 4.9 kg [10 lb 13oz]

Best Practice Guidelines

Condensation	It is strongly advised that the camera should not be used in a condensing atmosphere. If used in a condensing atmosphere the sensor MUST be protected and the use of a cold finger is strongly recommended.
Contamination and Damage	<ul style="list-style-type: none"> When not in use the sensor chamber should be covered and sealed. Due to the exposed nature of the sensor extreme care should be taken with the camera, as damage can easily occur through mishandling or by contamination. If due to accident or misuse the sensor becomes contaminated, please contact Andor immediately for advice on cleaning.
Vacuum Operations	Ensure that the vacuum environment to which the camera is fitted is free of water vapour and other contaminants. Care should also be taken to control pressure change, as sudden pressure changes can potentially cause damage to the sensor assembly. Before venting the vacuum chamber, the sensor must be allowed to warm up above the dew point.

Power Requirements For Classic SX DV series

CCI-010 MHz Operation	No PCI Flylead	PCI Flylead
No cooling slot connector	3 A	3 A
TE cooler on slot connector	1.5 A	0 A
	-	2.2 A
Total	4.5 A	5.2 A

Power drawn from +5V power supply, optional external power supply (PS150) plugs into mains with input maximum 2.2 A

Required cable clearance at the back:

Exit connector type	clearance
Standard	140 mm
45° angle	50 mm
90° angle	40 mm

Applications Guide

X-ray Laser Development
Lithography EUV
X-ray Plasma Diagnostics
Soft X-ray Imaging
X-ray Diffraction (XRD)
X-ray Fluorescence (XRF)
X-ray Spectroscopy
Phase Contrast Imaging



Order Today

Need more information? At Andor we are committed to finding the correct solution for you. With a dedicated team of technical advisors, we are able to offer you one-to-one guidance and technical support on all Andor products. For a full listing of our regional sales offices, please see: www.andor.com/contact

Our regional headquarters are:

Europe

Belfast, Northern Ireland
Phone +44 (28) 9023 7126
Fax +44 (28) 9031 0792

Japan

Tokyo
Phone +81 (3) 3518 6488
Fax +81 (3) 3518 6489

North America

Connecticut, USA
Phone +1 (860) 290 9211
Fax +1 (860) 290 9566

China

Beijing
Phone +86 (10) 5129 4977
Fax +86 (10) 6445 5401

Items shipped with your camera:

- 1 x 2 m SMB-BNC connection cable
- 1 x CD containing Andor user guides
- 1 x Individual system performance booklet
- 1 x Protective cover plate
- 4 x Fixing screws for cover plate

Footnotes: Specifications are subject to change without notice

1. IMPORTANT - Due to the sensor being exposed to environments outside of Andor's control there is no warranty on the sensor. For full details of Andor's Warranty Policy please refer to our webpage at http://www.andor.com/contact_us/support_request/. For key information on handling precautions for SX/HX in vacuum systems, please refer to the best practice guidelines on page 5. Note permanent damage can easily occur due to misuse.
2. Edge pixels may exhibit a partial response.
3. Stabilized cooling temperatures are given for slowest readout speed. Use of faster readout speeds (in order to achieve faster frame rates) may require a higher cooling temperature to be selected. Specified minimum air cooled temperature assumes ambient temperature of 25°C. Specified minimum temperature with coolant assumes coolant temperature of 10°C. All cooling performance can be compromised by the environment to which the sensor is exposed.
4. Figures are typical unless otherwise stated.
5. Dark current measurement is averaged over the CCD area excluding any regions of blemishes.
6. Readout noise is for the entire system and is taken as a mean over the sensor area excluding any regions of blemishes. It is a combination of sensor readout noise and A/D noise.
7. All sensors are designed to give optimum Charge Transfer Efficiency (CTE) at 16 μ S vertical pixel shift, some decrease in CTE may be observed at faster shift speeds.
9. Linearity is measured from a plot of counts vs exposure time under constant photon flux up to the saturation point of the system.
10. Quantum efficiency as supplied by the sensor manufacturer.
11. The graph shows photoelectrons generated as a function of photon energy of incident X-ray.

Minimum Computer Requirements:

- 3.0 GHz single core or 2.4 GHz dual or quad core processor
- 2 GB RAM
- 100 MB free hard disc to install software (at least 1GB recommended for data spooling)
- PCI-compatible computer, PCI slot must have bus master capability
- Windows (XP, Vista and 7) or Linux

Operating & Storage Conditions

Operating Temperature 0°C to 30°C ambient
Relative Humidity < 70% (non-condensing)
Storage Temperature -25°C to 50°C
Maximum Bakeout Temperature +55°C

Power Requirements

110 - 240 VAC, 50 - 60 Hz



Windows is a registered trademark of Microsoft Corporation.
Labview is a registered trademark of National Instruments.
Matlab is a registered trademark of The MathWorks Inc.

ClassicSXDV 0612 R1